

# RotaCol® - Ecoline Speedconnect PRECISION ANALOG CONTACTLESS ROTARY POSITION SENSORS - BUSH MOUNTING

Series 25A RS B  
Series 30A RS B

Ø25 mm & 30 mm plastic robust housing  
With stopper 320°  
Analog output - Current / voltage and PWM output  
Bush mounting, Shock and vibration proof  
Alternative to precision potentiometers  
Output connections - OCG, OCM, OCTA, OCTR



[www.rotacol.info/25arsb.pdf](http://www.rotacol.info/25arsb.pdf)

[www.rotacol.info/30arsb.pdf](http://www.rotacol.info/30arsb.pdf)

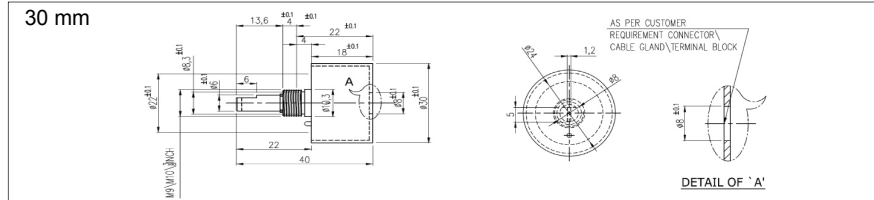
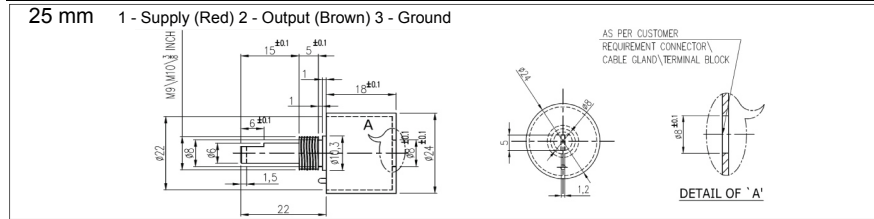

## ELECTRICAL CHARACTERISTICS

Electrical angle	0 to 360°, any angle from 0 - 20... 0 - 360 programmable in steps of 1°	
Resolution	4096 steps (12 bit)	
Independent linearity tolerance	± 0.5%	
Signal type	Supply voltage	Output signal
0505	5 V ±10%	0 - 5V ratiometric
DC05	9 - 30 V	0 - 5V
2410	15 - 30 V	0 - 10 V
2442	15 - 30 V	4 - 20 mA
2420	15 - 30 V	0 - 20 mA
PWM	5 V ±10%	PWM
Supply current	< 16 mA	
Update rate	1ms	

## MECHANICAL CHARACTERISTICS

Mechanical angle	(O) 360° (S) 320° +5° / - 0° with stop
Mechanical speed (max.)	800 rpm (brass) ; 3000 rpm (polymer)
Electrical speed (max.)	160 rpm
Life: with brass sleeve bearings	~ 10 million rotations
Life: with polymer sleeve bearings	~ 15 million rotations
End stop resistance	< 80 Ncm
Operating temperature	- 40 ... +85 °C
Operating torque (For medium.)	0.5-1Ncm (std)
Output connection	OCG, OCM, OCTA, OCTR
Vibration (IEC 68-2-6, Test Fc)	±1.5 mm / 20g / 2000Hz / 16cycles
Mechanical shock (IEC 68-2-7, Test Ea)	50g /11ms /half sine (3X6 shocks)
Weight	31 gm (25A RS B) / 47 gm (30A RS B)

## MATERIAL

Bearing standard	sleeve bearing- brass
Bearing type: option P	polymer sleeve bearing
Housing	Nylon 66 Glass fibre reinforced
Shaft	stainless steel

## OPTIONS AND ORDERING REFERENCE

Refer to electrical & mechanical options on page 2

xx	A	RS	Bx	Sxxxx	2C	0xxx/Sxxx	CW/CCW	PEx	POx	xT	P	D	Axx	CVxx	OCxx
25 / 30	A	RS	B1 B2 B3	S0505 S PWM S DC05 S 2410 S 2442 S 2420	2C	0360° S320°	CW CCW	PEX PE1 PE2 PE3 PE4	POX POZ POC POM	LT MT HT	P	D	Axx	CVxx	OCxx OCG OCM OCTA OCTR

Example with description - 25A RS B1 S0505 90 CW PE1 POZ A18 OCG -25 mm housing, analog output, Ecoline RotaCol Speedconnect, Bush mounting - Thread 10mm / 6mm shaft, 5V(ratiometric), 90° clockwise, delta 1/2, zero point, special shaft 18 mm, cable gland with 1 m cable - 3 core  
Standard Version : 360° CW Electrical & Mechanical angle, MT - Medium torque

## FUNCTION PRINCIPLE

The determination of angular position and signal generation is realised by an intelligent CMOS Hall sensor. A diametrical polarised magnet induces its magnetic field into the sensor. It rotates and provides a conditioned signal to the integrated electronic.

## ANALOG INTERFACE

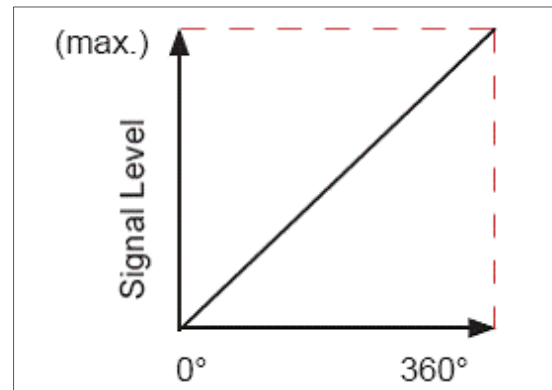

At the output of the sensor a variable voltage or variable current is provided proportional to the position of the shaft / axis over a complete angle range of 360° or a subrange. The contactless sensor electronic guarantees a steady signal level and a very low linearity failure of 0.3%. With supply voltages of 5VDC±10%; 9-30VDC; (24VDC) output signals of 0-5VDC; 0-10VDC; 0-20mA; 4-20mA at the sensor output are provided. A pulse-width modulated (PWM) signal can be generated by the analog interface. This signal can be processed by following connected electronics with PWM input.

For complete RotaCol Contactless Rotary Sensor product range refer - [www.rotacol.info/rotamec.pdf](http://www.rotacol.info/rotamec.pdf)

Please note: The specification and information in this datasheet cannot consider all special demands that are caused by the application. Because of this, they are no general description of the properties of the product. Megacraft does not assume any responsibility for damages due to improper application of our products. The user has to ensure on his own, that the products used are suitable for his application. Megacraft does not warrant the reproducibility of published information. The specifications can be changed any time without notice.

## ELECTRICAL OPTIONS FOR ANALOG VERSIONS 25/30A RS B

The following options are electrically programmable & are available very cost effective, with short delivery time

### Non-effective Electrical Angle (PE1) - Delta 1/2

If the electrical effective angle is programmed smaller than 360°, the remaining electrical non-effective angle is divided in two equal parts : high level & low level (Delta 1/2)

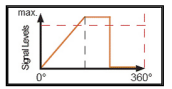

### Low level (PE2)

If the electrical effective angle is programmed smaller than 360°, after reaching the maximum, the signal level falls to low level.

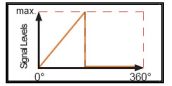

### High level (PE3)

If the electrical angle is programmed smaller than 360°, the signal level remains high after reaching the full level.

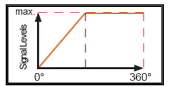

### Variable level (PE4)

If the electrical angle is programmed smaller than 360°, remaining electrical non effective angle can be divided into high and low level in any ratio according to customer request.

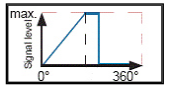

### Direction of Rotation (CW/CCW)

By default the direction of rotation is clockwise (CW). With this option it is also possible to change the direction from clockwise(CW) to counterclockwise (CCW).

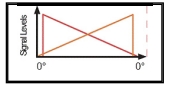

### Zero point Programming (POZ)

Mechanical zero point is aligned with marking on the sensor housing. Electrical zero point can be aligned to mechanical zero point. Zero point can be programmed at any offset.

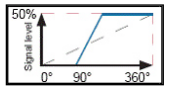

### Center Point Programming (POC)

Effective electrical angle is aligned with the mechanical zero point in such a way that equal effective angles in both rotating directions are achieved. Center point can be programmed at any offset.

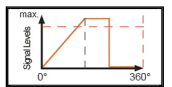

### Multi Point Programming (POM)

Output characteristics : 3 to 6 rising or falling linear segments. Min and max signal level can be defined within the total electrical angle. First and last linear segment (min/max) is always horizontal. 1 to 3 settable calibration points.

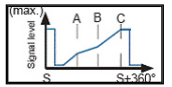

### Pulse Width Modulation (PWM)

PWM provides a constant carrier frequency which defines high to low ratio. The ratio between high & low corresponds to the signal characteristics. It is in a fixed relation to the angle. Generally, for further signal processing, no A/D converter is required because many microcontrollers already have PWM input (valid only for 0505 output).

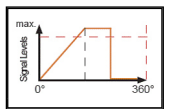

### 2 Channel Redundant Output (2C)

This is realized by a Hall sensor chip consisting of 2 galvanically separated sensing elements. One magnet provides a magnetic field simultaneously for both elements. Both elements can be programmed identically, or channel 2 can also be programmed independently from channel 1. (Valid only for 0505, DC05, and 2410 outputs).

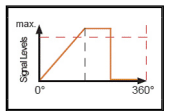

## MECHANICAL OPTIONS FOR ANALOG VERSIONS 25/30A RS B

Type / Series	Standard mechanical options	Customized mechanical options
25 / 30A RS B	Low torque (LT) ; High torque (HT) ; Endstop at 90 °, 180 °, 270 °, 320 °	Special shaft length ; Special endstop angle

## SPEEDCONNECT OUTPUT CONNECTIONS FOR ANALOG VERSIONS 25/30A RS B

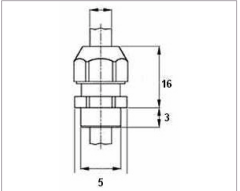
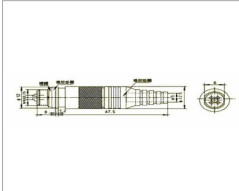
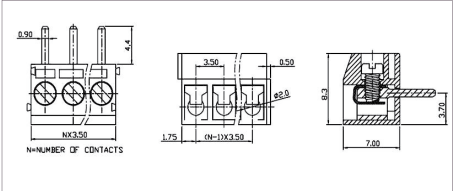
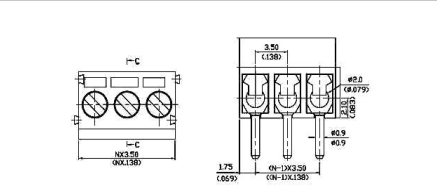
Cable gland (OCG)	Miniature connector (OCM)	Terminal block - Axial (OCTA) Wires leaving axial to shaft axis	Terminal block - Radial (OCTR) Wires leaving radial to shaft axis
3 core cable of 1 m length	3 pin in integrated socket with plug	3 sockets	3 sockets
			

### European Sales & Technical Support

**MegAuto KG**  
 Am Tummelsgrund 48  
 D 01156 Dresden, Germany  
 Tel : +49 351 6587894 0 Fax : +49 351 6587894 9  
 Email : info@megauto.de / www.megauto.de  
 a MegAuto Group Company

### Worldwide Technical & Marketing Center

**MegAuto International, Sensall Division**  
 Div of Sendap Precision Electronics Pvt Ltd.  
 3, Electronic Sadan - I, MIDC, Bhosari, Pune - 411026, INDIA  
 Tel : +91 20 30681190 , +91 20 30626126  
 Email : mail@megacraft.net / www.sensall.info  
 a MegAuto Group Company

